

# ROSTA TENSIONER DEVICES

**Maintenance-free Tensioning Devices for Belt and Chain Drives**

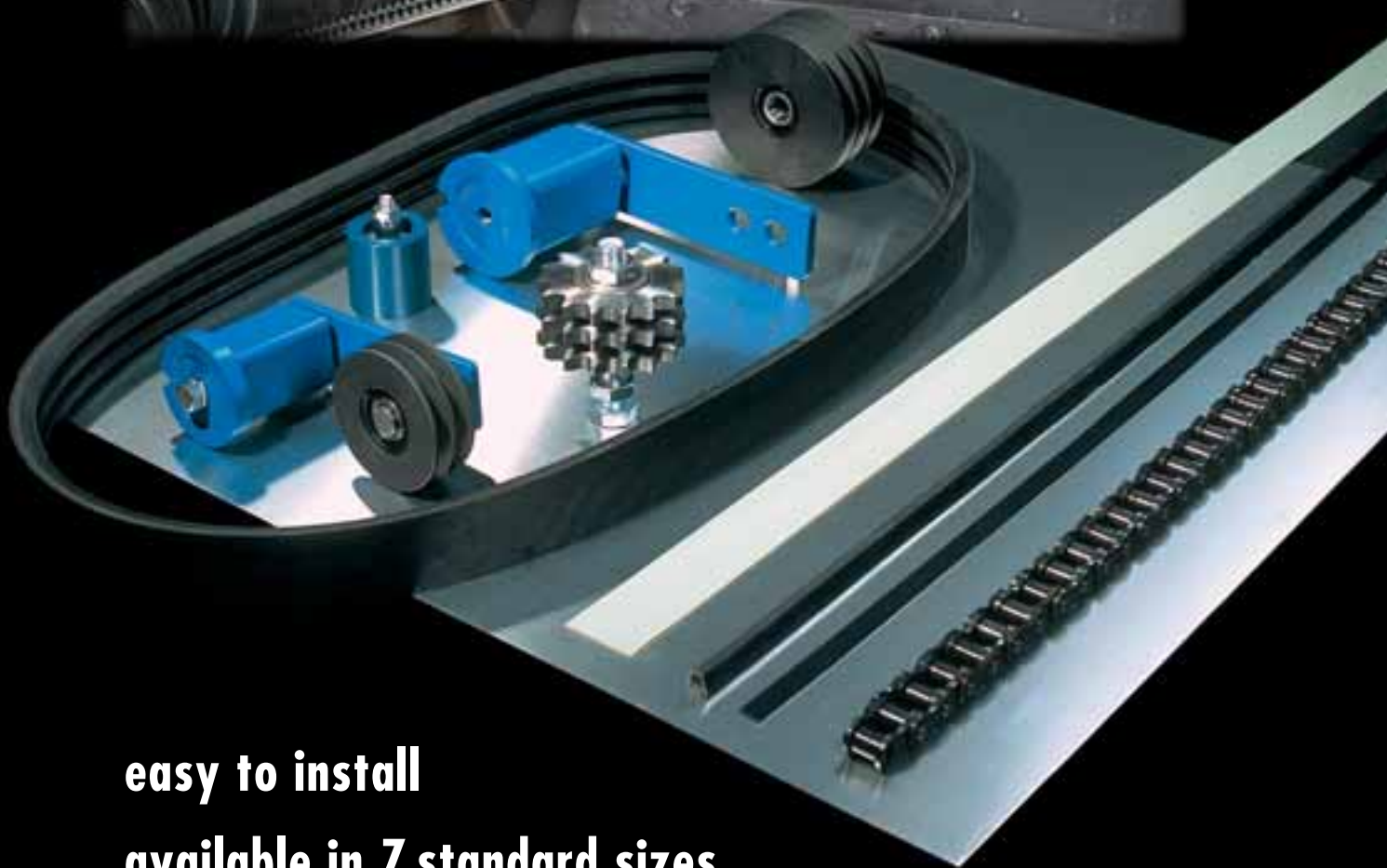

**easy to install**

**available in 7 standard sizes**

**wide range of accessories  
available**

**ROSTA** 



## Tensioning Technology

### Chain Tensioning

Roller chains are power transmission components with positive transmission which, by virtue of their design are subject, depending on quality, to elongation as a result of wear of 1 to 3% of their total length. In spite of this elongation, due to aging, a roller chain transmits the occurring torques effectively providing it is periodically retensioned. Without tension adjustment, the slack side of the chain becomes steadily longer, oscillates and reduces the force transmitting wrap angle of the chain on the chain wheels. The chain no longer runs smoothly off the teeth of the chain wheels, producing uneven running of the entire drive and supporting wear (polygon effect). The service life of the chain drive can be extended considerably by the use of an automatic chain tension adjuster.

The ROSTA tensioning element prevents the slack side of the chain from "sagging" or "slapping" by its automatic operation and very wide tensioning range for compensating this given elongation. The ROSTA tensioning element is based on the ROSTA rubber spring principle. **According to application it is supplemented with the appropriate sprocket wheel or chain rider set for chain drives or with the belt roller or pulley in belt tensioner applications** (see page 35 "Product Range" or page 40 "Allocation Table"). **Assembling of the sprocket wheel and chain rider sets or the belt roller on the tensioning element is carried out on the customer's side.**

### Pretensioning

With the ROSTA tensioning element the necessary travel and simultaneously the corresponding initial tension force can be accurately adjusted by a torsion angle scale and

indicating arrow. Excessive initial pretensioning of the chain should be avoided in order to reduce the tensile force and surface pressure on the links.

### Vibration Damping

The ROSTA tensioning element, based on a system of rubber springs, absorbs considerably the chain vibration due to internal molecular friction in the rubber inserts. The rubber spring effectively absorbs the vibrations, resulting from the polygon effect, which also positively influences the noise level of the complete chain drive.

### Installation

The sprocket wheel or chain rider is installed in arm position "normal" or "hard" in the required position and secured with the supplied nuts.

The laterally adjustable bearing on the thread permits simple and rapid adjustment of the wheel or rider to the chain track. The central fixing of the tensioning element with a single screw saves a great deal of time in installation. In addition, only one fixing hole is required on the "machine side".

On smooth, clean and torsionally rigid surfaces the resistance of the frictional contact between the tensioner housing and the machine element is a **multiple** of the maximum initial tensioning torque at 30°. In almost all applications therefore, any additional securing of the tensioner housing can be dispensed. Only with rough, uneven or highly corroded mounting surfaces could the torsional resistance be insufficient on account of the **point application** nature of the frictional contact. In these exceptional cases we recommend the mounting of a locking pin through the positioning notch on to the machine structure.

## Superior Technology

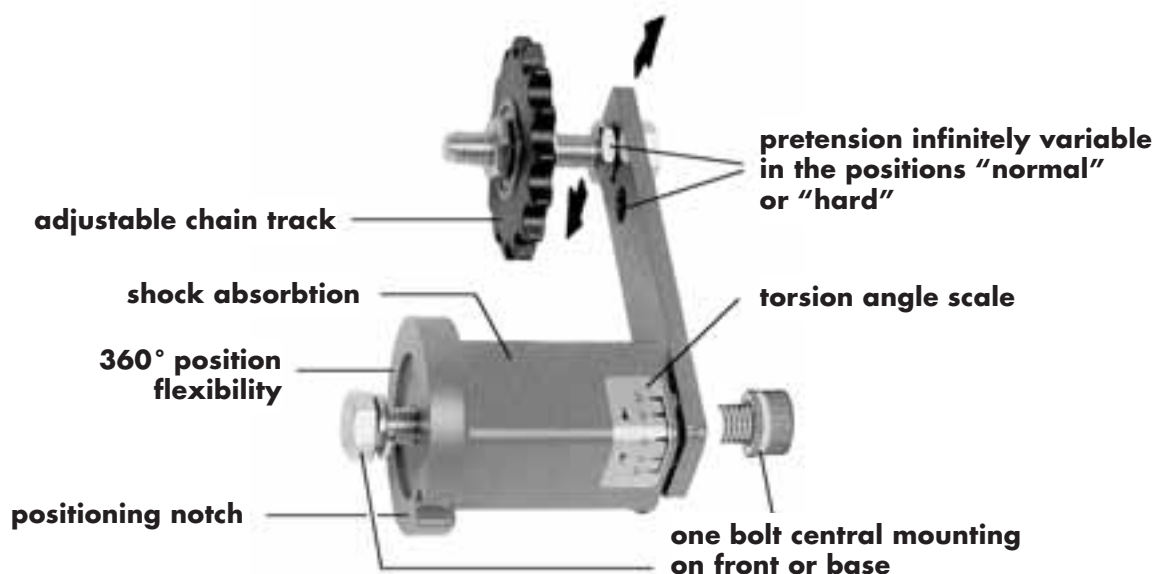



## Product Range

### ROSTA Tensioning Element Type SE, SE-G, SE-W

Page 37

The tensioning element with the specification SE (SE 11 to SE 50) is the mostly used standard unit for tensioning all kind of chain and belt drives. The elastomeric inserts based on a high elastic natural rubber with a good shape memory. This unit is designed for applications in temperatures from  $-40^{\circ}\text{C}$  to  $+80^{\circ}\text{C}$  ( $-40^{\circ}\text{F}$  to  $+180^{\circ}\text{F}$ ).

The tensioning element type SE-G (marked with yellow dot) has zinc-plated steel parts and therefore is specially designed for "outdoor" applications; e.g. for building machines. In addition, the type SE-G is equipped with oil resistant synthetic inserts for applications in oily areas, like in gear-boxes and crank-cases.

The tensioning element type SE-W (marked with red dot) is equipped with heat resistant elastomeric inserts. It is developed for applications in temperatures from  $+80^{\circ}\text{C}$  to  $+120^{\circ}\text{C}$  ( $+180^{\circ}\text{F}$  to  $+250^{\circ}\text{F}$ ), such as belt tensioners for diesel engines, chain tensioner in driers, belt scraper in hot surroundings, etc. Due to the characteristics of the elastomeric compound, the resulting tension pressure of the type SE-W reduces by 40%, compared to the standard type SE and the type SE-G.



### ROSTA Tensioning Element Type SE-F

Page 38

The ROSTA tensioning element type SE-F is designed for front mounting applications on "blind" frame structures. Rubber quality, tensioning pressure, material and surface protection are identical to the type SE. The special fixation screw with distance bushing is zinc-plated and secured in the housing by means of a rubber O-ring.



### ROSTA Tensioning Element Type SEI (Inox)

Page 38

The ROSTA tensioning elements type SEI are all made out of stainless steel. They are available off-the-shelf in four different sizes: SEI 15, 18, 27, housing in SS casted version, SEI 40 (similar to SE 38), housing in SS welded version. The stainless steel quality complies with the DIN 1.4301 and AISI 304 specifications. These tensioning elements have been primarily designed for applications in the food industry and the chemical process technology. Type SEI 40 is only available with the standard rubber inserts, type "Rubmix 10".



### ROSTA Tensioning Element Type SE-B "Boomerang"

Page 39

The ROSTA tensioning element type SE-B "Boomerang" compensates the slack in extremely long chain drives. The "Boomerang" with its bended double arm, equipped with two sprocket wheels, offers a triple compensation of the slack.



### ROSTA V-Belt Tensioner Type KSE

Page 39

The modified ROSTA tensioning element type SE 18, 27, 38 with a welded in steel axle is equipped with a standardized V-belt pulley in single, double and triple groove version for standard V-belts type SPZ, SPA and SPB. Pulleys made out of iron gray cast are equipped with quality ball bearings and are available off-the-shelf in the mentioned single, double or triple versions.



### Accessories for Tensioning Element Type SE

#### Sprocket Wheel Set Type "N"

Page 41

The ROSTA sprocket wheel set completes the tensioning element for applications in chain drives. The sprocket wheel runs on a self-lubricating ball bearing 2Z.

#### Chain Rider Set Type "P"

Page 42

The ROSTA chain rider set, assembled on the tensioning element, is a low-cost and low noise alternative for tensioning chain drives. The high-quality rider is made of friction resistant industrial plastic and allows the use on both rider sides. The max. permissible chain speed should not exceed 1.5 m/sec.

Synthetic material: POM-H

#### Tensioning Roller Type "R"

Page 42

The roller is made of industrial plastic material (polyamide) with two self-lubricating ball bearings 2Z. Synthetic material: PA 6





## Selection (sizing) of ROSTA Tensioner Type SE for V-Belt Drives

The required tensioner arm should have a pressure capacity of at least + 100 % of the relevant belt testforce for the particular V-belt section (for multiple belt drives = x times belt number)

### a) Tension on back (side) of the belt with a flat roller (V-belt)

The roller diameter should have at least  $\frac{2}{3}$  of the smaller pulley diameter.

The roller width should be 20% wider than the belt-back; for multiple belt drives = + 20% of the total belt-back-widths.

### b) Tension from inside with grooved pulley

The position of the tensioner pulley has to be closer at the driven pulley in order to avoid an important diminution of the angle of circumference on the usually smaller drive-pulley.

### c) Selection of the ROSTA tensioner arm

1. Check the test force of the relevant belt section (e.g. type SPC = 90 N).
2. Multiply the test force with the quantity of belts (e.g. 5 section SPC-belts =  $5 \times 90 \text{ N} = 450 \text{ N}$ ).
3. Add 100% on the cumulated test force in order to avoid any belt slippage when starting up (e.g.  $2 \times 450 \text{ N} = 900 \text{ N}$ ).
4. Select a ROSTA tensioner offering approx. 900 N at pretension angle of  $20^\circ$  (e.g. = SE 38 or SE 45).
5. Set the tensioner at a pretension angle of  $25^\circ$  on the slack of the belt drive ( $25^\circ$  in order to compensate the initial important elongation).

## Tensioning force can be set continuously

Tensioner types	pre-tension $\curvearrowright 10^\circ$ normal		pre-tension $\curvearrowright 20^\circ$ normal		pre-tension $\curvearrowright 30^\circ$ normal		
	F in N	s in mm	F in N	s in mm	F in N	s in mm	
SE/SE-G	11	15	14	40	28	80	40
SE/SE-F/SE-G	15	25	17	65	34	135	50
SE-W	15	15	17	39	34	81	50
SE/SE-F/SE-G	18	75	17	180	34	350	50
SE-W	18	45	17	108	34	210	50
SE/SE-F/SE-G	27	150	22	380	44	800	65
SE-W	27	90	22	228	44	480	65
SE/SE-F/SE-G	38	290	30	730	60	1500	87
SE-W	38	174	30	438	60	900	87
SE/SE-F/SE-G	45	500	39	1300	78	2600	112
SE-W	45	300	39	780	78	1560	112
SE/SE-F/SE-G	50	750	43	2150	86	4200	125
SE-W	50	450	43	1290	86	2520	125

s = pre-tensioning gap

## Tensile Control Forces for V-Belts

(Examples for most usual V-belts)

Belt types	$\varnothing$ Small pulley in mm	Control force* in N
SPZ (10 N)	56 – 95 100 – 140	12 – 15 17 – 20
SPA (13 N)	100 – 132 140 – 200	25 – 27 30 – 35
SPB (16 N)	160 – 224 236 – 315	45 – 50 60 – 65
SPC (22 N)	224 – 355 375 – 560	80 – 90 100 – 120
10 x 6 (Z)	56 – 100	12 – 15
13 x 8 (A)	80 – 140	12 – 15
17 x 11 (B)	125 – 200	25 – 30
22 x 14 (C)	200 – 400	55 – 60
32 x 20 (D)	355 – 600	90 – 105

\* Tensile control force for V-belts. By ideal belt pretension a deflection of 16 mm per 1000 mm center distance shall occur. (By shorter or longer span, the value 16 mm has to be interpolated.)

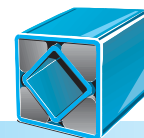

## Tensioner Device

## Type SE/SE-G/SE-W

### Standard Mounting

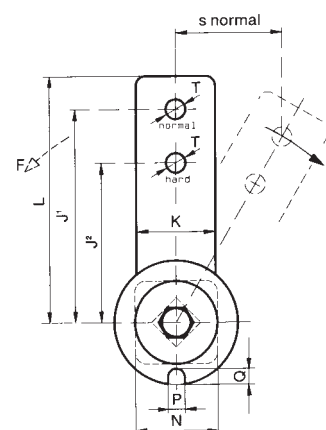
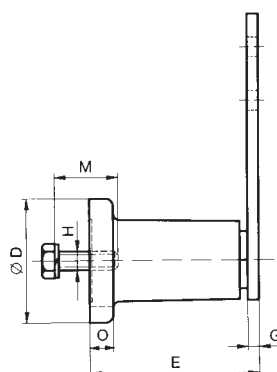
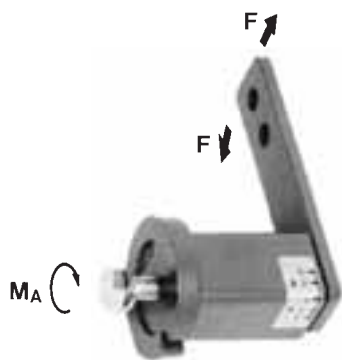

### Technical Data

Art. No.	Type**	F max.* in N of position normal (J <sup>1</sup> )	s max. in mm normal	Torque M <sub>A</sub> in Nm	Weight in kg
<b>06011001</b>	<b>SE 11</b> (Standard)	<b>80</b>	<b>40</b>	10	0.20
06013201	SE 11-G	80	40	10	0.20
<b>06011002</b>	<b>SE 15</b> (Standard)	<b>135</b>	<b>50</b>	25	0.40
06013202	SE 15-G	135	50	25	0.40
06015002	SE 15-W	81	50	25	0.40
<b>06011003</b>	<b>SE 18</b> (Standard)	<b>350</b>	<b>50</b>	49	0.60
06013203	SE 18-G	350	50	49	0.60
06015003	SE 18-W	210	50	49	0.60
<b>06011004</b>	<b>SE 27</b> (Standard)	<b>800</b>	<b>65</b>	86	1.70
06013204	SE 27-G	800	65	86	1.70
06015004	SE 27-W	480	65	86	1.70
<b>06011005</b>	<b>SE 38</b> (Standard)	<b>1500</b>	<b>87.5</b>	210	3.55
06013205	SE 38-G	1500	87.5	210	3.55
06015005	SE 38-W	900	87.5	210	3.55
<b>06011006</b>	<b>SE 45</b> (Standard)	<b>2600</b>	<b>112.5</b>	410	6.40
06013206	SE 45-G	2600	112.5	410	6.40
06015006	SE 45-W	1560	112.5	410	6.40
<b>06011007</b>	<b>SE 50</b> (Standard)	<b>4200</b>	<b>125</b>	750	9.00
06013207	SE 50-G	4200	125	750	9.00
06015007	SE 50-W	2520	125	750	9.00

\* F max. in position "hard" approx. 25% higher

### Dimensions

Art. No.	Type**	D	E	G	H	J <sup>1</sup>	J <sup>2</sup>	K	L	M	N	O	P	Q	T
<b>06011001</b>	<b>SE 11</b>	35	51 <sup>+1</sup> <sub>-0.5</sub>	5	M6	80	60	20	90	20	22	6	8	5	8.5
06013201	SE 11-G														
<b>06011002</b>	<b>SE 15</b>	45	64 <sup>+1</sup> <sub>-0.5</sub>	5	M8	100	80	25	112.5	25	30	8	8.5	6	10.5
06013202	SE 15-G														
06015002	SE 15-W														
<b>06011003</b>	<b>SE 18</b>	58	79 <sup>+1.5</sup> <sub>-0.5</sub>	7	M10	100	80	30	115	30	35	10.5	8.5	8	10.5
06013203	SE 18-G														
06015003	SE 18-W														
<b>06011004</b>	<b>SE 27</b>	78	108 <sup>+2</sup> <sub>-0.5</sub>	8	M12	130	100	50	155	40	52	15	10.5	10	12.5
06013204	SE 27-G														
06015004	SE 27-W														
<b>06011005</b>	<b>SE 38</b>	95	140 <sup>+2</sup> <sub>-0.5</sub>	10	M16	175	140	60	205	40	66	15	12.5	12	20.5
06013205	SE 38-G														
06015005	SE 38-W														
<b>06011006</b>	<b>SE 45</b>	115	200 <sup>+3</sup>	12	M20	225	180	70	260	50	80	18	12.5	12	20.5
06013206	SE 45-G														
06015006	SE 45-W														
<b>06011007</b>	<b>SE 50</b>	130	210 <sup>+3</sup>	20	M24	250	200	80	290	60	87	20	17	17	20.5
06013207	SE 50-G														
06015007	SE 50-W														

\*\* Type SE: Standard quality – Surface painted  
 Type SE-G: Oil resistant – Surface zinc-plated (with yellow mark)  
 Type SE-W: Heat resistant – Surface painted (with red mark)

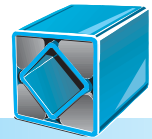

## Tensioner Device

## Type SE-F/SEI

### ROSTA Tensioner Device Type SE-F (Front Mounting)

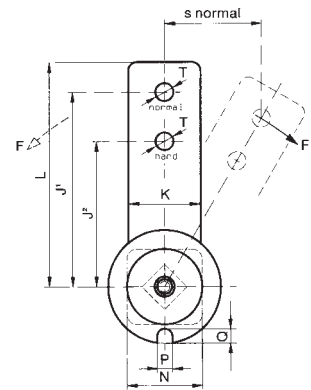
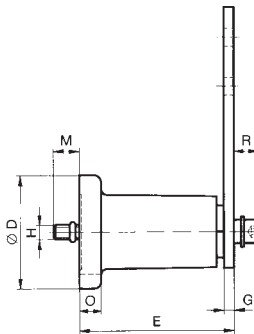
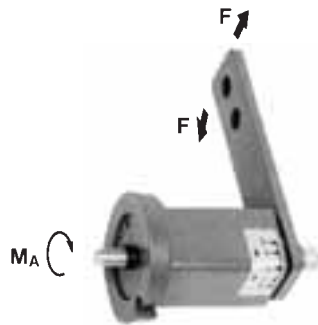

#### Technical Data

Art. No.	Type	F max.* in N of position normal (J <sup>1</sup> )	s max. in mm normal	Torque M <sub>A</sub> in Nm	Weight in kg
06061002	SE-F 15	135	50	17	0.40
06061003	SE-F 18	350	50	41	0.65
06061004	SE-F 27	800	65	83	1.85
06061005	SE-F 38	1500	87.5	145	3.70
06061006	SE-F 45	2600	112.5	355	6.90
06061007	SE-F 50	4200	125	690	10.10

\* F max. in position "hard" approx. 25% higher

#### Dimensions

Art. No.	Type	D	E	G	H	J <sup>1</sup>	J <sup>2</sup>	K	L	M	N	O	P	Q	R	T
06061002	SE-F 15	45	64 <sup>+1</sup> <sub>-0.5</sub>	5	M6	100	80	25	112.5	12.4	30	8	8.5	6	10	10.5
06061003	SE-F 18	58	79 <sup>+1.5</sup> <sub>-0.5</sub>	7	M8	100	80	30	115	18.9	35	10.5	8.5	8	12	10.5
06061004	SE-F 27	78	108 <sup>+2</sup> <sub>-0.5</sub>	8	M10	130	100	50	155	17.5	52	15	10.5	10	16	12.5
06061005	SE-F 38	95	140 <sup>+2</sup> <sub>-0.5</sub>	10	M12	175	140	60	205	18.0	66	15	12.5	12	19	20.5
06061006	SE-F 45	115	200 <sup>+3</sup> <sub>-1</sub>	12	M16	225	180	70	260	33.0	80	18	12.5	12	27	20.5
06061007	SE-F 50	130	210 <sup>+3</sup> <sub>-1</sub>	20	M20	250	200	80	290	23.0	87	20	17	17	28	20.5

### ROSTA Tensioner Device Type SEI (Stainless Steel)

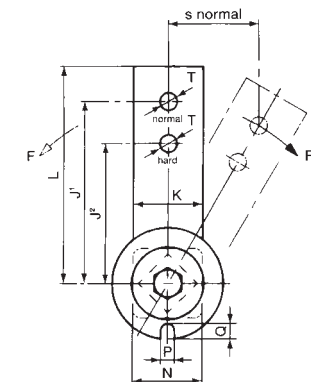
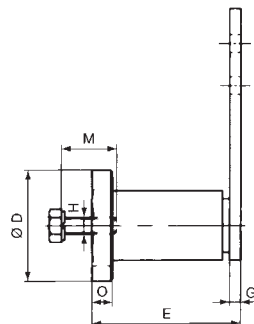
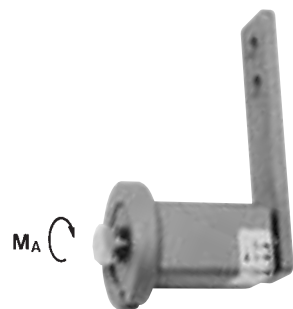

#### Technical Data

Art. No.	Type	F max.* in N of position normal (J <sup>1</sup> )	s max. in mm normal	Torque M <sub>A</sub> Nm	Weight in kg
06071111	SEI 15	150	50	25	0.41
06071112	SEI 18	400	50	49	0.70
06071113	SEI 27	860	65	86	2.13
06071104	SEI 40	1500	87.5	210	4.29

\* F max. in position "hard" approx. 25% higher

#### Dimensions

Art. No.	Type	D	E	G	H	J <sup>1</sup>	J <sup>2</sup>	K	L	M	N	O	P	Q	T
06071111	SEI 15	45	64	5	M 8	100	80	25	112.5	25	30	8	8.5	6	10.5
06071112	SEI 18	58	79	7	M10	100	80	30	115	30	35	10.5	8.5	8	10.5
06071113	SEI 27	78	108	8	M12	130	100	50	155	40	52	15	10.5	10	12.5
06071104	SEI 40	100	140	10	M16	175	140	70	205	40	70	15	12.5	12	20.5



## Tensioner Device

## Type SE-B / KSE

### ROSTA Tensioner Device Type SE-B

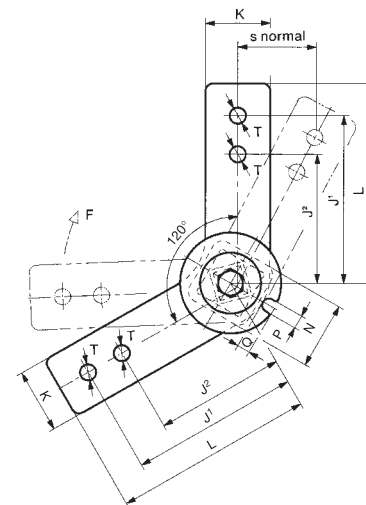
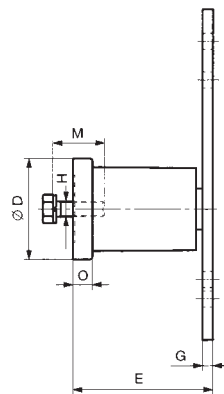
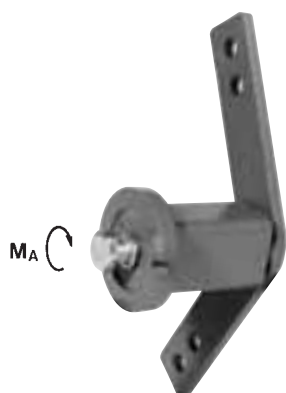

Please see table on page 37 for more technical information

Art. No.	Type	F max.* in N of position normal (J')	s max. in mm normal	Torque $M_A$ in Nm	Weight in kg
06 021 003	SE-B 18	175	50	49	0.75
06 021 004	SE-B 27	400	65	86	2.10

\* F max. in position "hard" approx. 25% higher

### ROSTA V-Belt Tensioner Device Type KSE

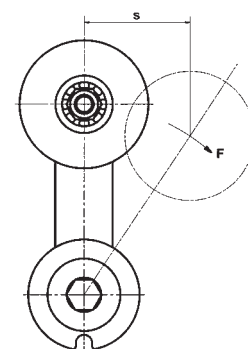
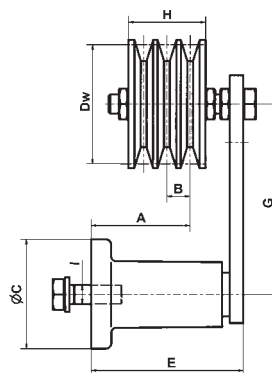

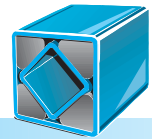

Please see table on page 37 for more technical information

Art. No.	Type	number of grooves	max. speed n/min.	F max. in N	s max. in mm	A	B	$\varnothing C$	Dw	E	G	H	I	Weight in kg
06 201 001	KSE 18-SPZ	1	10000	350	50	39-54	12	58	63	79	100	28	M10	1.0
06 201 002	KSE 18-SPZ	2	10000	350	50	37-54	12	58	63	79	100	35	M10	1.2
06 201 003	KSE 18-SPZ	3	10000	350	50	48-54	12	58	63	79	100	40	M10	1.4
06 201 004	KSE 27-SPA	1	7400	800	65	47-77	15	78	90	108	130	36	M12	2.6
06 201 005	KSE 27-SPA	2	7400	800	65	61-77	15	78	90	108	130	45	M12	3.2
06 201 006	KSE 27-SPA	3	7400	800	65	58-77	15	78	90	108	130	60	M12	3.7
06 201 007	KSE 27-SPB	1	5300	800	65	48-77	19	78	125	108	130	36	M12	3.8
06 201 008	KSE 27-SPB	2	5300	800	65	48-75	19	78	125	108	130	55	M12	5.3
06 201 009	KSE 38-SPB	3	4000	1500	87.5	84-97	19	95	125	140	175	63	M16	8.3

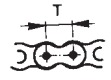

## Allocation Table

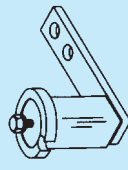
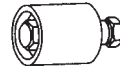
						max. belt width
DIN 8187 ISO R606	T x width	Type N	Type P	Size SE	Type R	
06 B-1	<b>3/8" x 7/32"</b>		3/8"-8 S	11	11	30
06 B-1	3/8" x 7/32"	3/8"-10 S		15/18		
06 B-2	3/8" x 7/32"	3/8"-10 D		15/18		
06 B-2	3/8" x 7/32"		3/8"-8 D	11		
06 B-3	3/8" x 7/32"	3/8"-10 T		18		
08 B-1	<b>1/2" x 5/16"</b>	1/2"-10 S	1/2"-10 S	15/18	15/18	40
08 B-2	1/2" x 5/16"	1/2"-10 D	1/2"-10 D	15/18		
08 B-3	1/2" x 5/16"	1/2"-12 T		27		
10 B-1	<b>5/8" x 3/8"</b>		5/8"-10 S	18		
10 B-1	5/8" x 3/8"	5/8"-12 S		27	27	55
10 B-2	5/8" x 3/8"		5/8"-10 D	18		
10 B-2	5/8" x 3/8"	5/8"-12 D		27		
10 B-3	5/8" x 3/8"	5/8"-12 T		27		
10 B-3	5/8" x 3/8"	5/8"-20 T		38		
12 B-1	<b>3/4" x 7/16"</b>	3/4"-12 S	3/4"-12 S	27		
12 B-1	3/4" x 7/16"	3/4"-20 S		38	38	85
12 B-2	3/4" x 7/16"	3/4"-12 D	3/4"-12 D	27		
12 B-2	3/4" x 7/16"	3/4"-20 D		38		
12 B-3	3/4" x 7/16"	3/4"-20 T		38		
16 B-1	<b>1" x 17 mm</b>	1"-20 S		38		
16 B-2	1" x 17 mm	1"-20 D		38		
16 B-3	1" x 17 mm	1"-20 T		45	45	130
20 B-1	<b>1 1/4" x 3/4"</b>	1 1/4"-20 S		45		
20 B-2	1 1/4" x 3/4"	1 1/4"-20 D		45/50		
20 B-3	1 1/4" x 3/4"	1 1/4"-20 T		45/50		
24 B-1	<b>1 1/2" x 1"</b>	1 1/2"-20 S		45		
24 B-2	1 1/2" x 1"	1 1/2"-20 D		45/50		
24 B-3	1 1/2" x 1"	1 1/2"-20 T		45/50		
32 B-1	<b>2" x 1 1/4"</b>			50		
32 B-2	2" x 1 1/4"			50		
32 B-3	2" x 1 1/4"			50		

## Example for Selection

### Given:

Chain drive with 1"-Duplex roller chain 16B-2 according DIN 8187. Tensioner has to be mounted onto a hollow steel structure (front mounting), temperature range normal, max. +80°C, no special surface treatment necessary.

### Selected:

ROSTA Tensioner Device SE-F 38 Art. No. 06 061 005  
and  
ROSTA Sprocket wheel set N 1"-20 D Art. No. 06 520 006





## Sprocket Wheel Set

## Type N

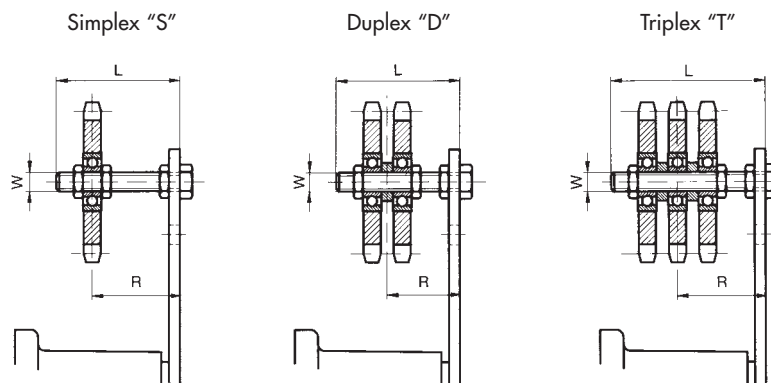

Art. No.	Type	Roller chain DIN 8187	Number of teeth	W	L	Adjusting range track*		Weight in kg
						R		
<b>Simplex "S"</b>								
06 510 001	N <sup>3</sup> / <sub>8</sub> "-10 S	ISO 06 B-1	15	M10	55	22-43/23-43		0.15
06 510 002	N <sup>1</sup> / <sub>2</sub> "-10 S	ISO 08 B-1	15	M10	55	23-44		0.20
06 510 003	N <sup>5</sup> / <sub>8</sub> "-12 S	ISO 10 B-1	15	M12	80	27-65		0.35
06 510 004	N <sup>3</sup> / <sub>4</sub> "-12 S	ISO 12 B-1	15	M12	80	27-65		0.55
06 510 005	N <sup>3</sup> / <sub>4</sub> "-20 S	ISO 12 B-1	15	M20	100	40-80		0.85
06 510 006	N1"-20 S	ISO 16 B-1	13	M20	100	40-80		1.25
06 510 007	N1 <sup>1</sup> / <sub>4</sub> "-20 S	ISO 20 B-1	13	M20	100	40-80/48-80		2.00
06 510 008	N1 <sup>1</sup> / <sub>2</sub> "-20 S	ISO 24 B-1	11	M20	140	40-120/48-120		2.35
<b>Duplex "D"</b>								
06 520 001	N <sup>3</sup> / <sub>8</sub> "-10 D	ISO 06 B-2	15	M10	55	27-39/28-39		0.20
06 520 002	N <sup>1</sup> / <sub>2</sub> "-10 D	ISO 08 B-2	15	M10	55	30-37		0.35
06 520 003	N <sup>5</sup> / <sub>8</sub> "-12 D	ISO 10 B-2	15	M12	80	36-57		0.60
06 520 004	N <sup>3</sup> / <sub>4</sub> "-12 D	ISO 12 B-2	15	M12	80	37-56		1.05
06 520 005	N <sup>3</sup> / <sub>4</sub> "-20 D	ISO 12 B-2	15	M20	120	50-90		1.35
06 520 006	N1"-20 D	ISO 16 B-2	13	M20	120	55-84		2.10
06 520 007	N1 <sup>1</sup> / <sub>4</sub> "-20 D	ISO 20 B-2	13	M20	140	60-120/68-120		3.60
06 520 008	N1 <sup>1</sup> / <sub>2</sub> "-20 D	ISO 24 B-2	11	M20	140	65-97/73-97		4.25
<b>Triplex "T"</b>								
06 530 001	N <sup>3</sup> / <sub>8</sub> "-10 T	ISO 06 B-3	15	M10	70	33-48		0.25
06 530 002	N <sup>1</sup> / <sub>2</sub> "-12 T	ISO 08 B-3	15	M12	80	41-51		0.50
06 530 003	N <sup>5</sup> / <sub>8</sub> "-12 T	ISO 10 B-3	15	M12	80	43-50		0.95
06 530 004	N <sup>5</sup> / <sub>8</sub> "-20 T	ISO 10 B-3	15	M20	120	56-84		1.25
06 530 005	N <sup>3</sup> / <sub>4</sub> "-20 T	ISO 12 B-3	15	M20	120	59-80		1.50
06 530 006	N1"-20 T	ISO 16 B-3	13	M20	160	74-108		2.90
06 530 007	N1 <sup>1</sup> / <sub>4</sub> "-20 T	ISO 20 B-3	13	M20	160	78-105/86-105		5.20
06 530 008	N1 <sup>1</sup> / <sub>2</sub> "-20 T	ISO 24 B-3	11	M20	180	90-111/98-111		6.20

\* for SE sizes, please see table on page 40

## Sprocket Wheel Type N

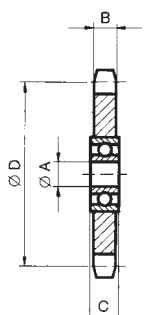

Art. No.	Type	Roller chain DIN 8187	Number of teeth					Weight in kg
				A	B	C	D	
06 500 001	N <sup>3</sup> / <sub>8</sub> "-10	ISO 06 B	15	10	5.3	9	45.81	0.06
06 500 002	N <sup>1</sup> / <sub>2</sub> "-10	ISO 08 B	15	10	7.2	9	61.08	0.15
06 500 003	N <sup>1</sup> / <sub>2</sub> "-12	ISO 08 B	15	12	7.2	12	61.08	0.15
06 500 004	N <sup>5</sup> / <sub>8</sub> "-12	ISO 10 B	15	12	9.1	12	76.36	0.27
06 500 005	N <sup>5</sup> / <sub>8</sub> "-20	ISO 10 B	15	20	9.1	15	76.36	0.29
06 500 006	N <sup>3</sup> / <sub>4</sub> "-12	ISO 12 B	15	12	11.1	12	91.63	0.47
06 500 007	N <sup>3</sup> / <sub>4</sub> "-20	ISO 12 B	15	20	11.1	15	91.63	0.47
06 500 008	N1"-20	ISO 16 B	13	20	16.1	15	106.14	0.88
06 500 009	N1 <sup>1</sup> / <sub>4</sub> "-20	ISO 20 B	13	20	18.5	15	132.67	1.60
06 500 010	N1 <sup>1</sup> / <sub>2</sub> "-20	ISO 24 B	11	20	24.1	15	135.23	1.93



## Chain Rider Set

## Type P

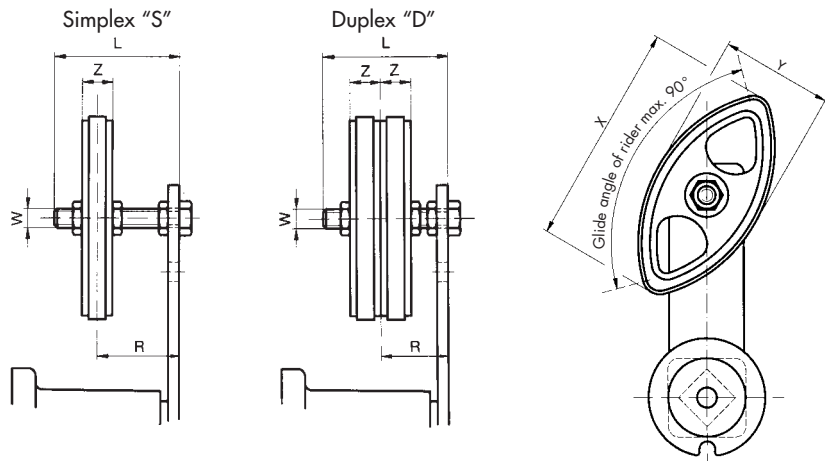

### Technical Data

Art. No.	Type	Roller chain DIN 8187	W	L	X	Y	Z	Adjusting range track* R	Weight in kg
<b>Simplex "S"</b>									
06 550 001	P <sup>3/8"</sup> - 8 S	ISO 06 B-1	M8	45	74	37	10.2	19-34	0.05
06 550 002	P <sup>1/2"</sup> -10 S	ISO 08 B-1	M10	55	96	48	13.9	23-41	0.10
06 550 003	P <sup>5/8"</sup> -10 S	ISO 10 B-1	M10	55	126	63	16.6	24-39	0.12
06 550 004	P <sup>3/4"</sup> -12 S	ISO 12 B-1	M12	80	148	72	19.5	30-61	0.18
<b>Duplex "D"</b>									
06 560 001	P <sup>3/8"</sup> - 8 D	ISO 06 B-2	M8	45	74	37	10.2	25-30	0.07
06 560 002	P <sup>1/2"</sup> -10 D	ISO 08 B-2	M10	55	96	48	13.9	30-34	0.12
06 560 003	P <sup>5/8"</sup> -10 D	ISO 10 B-2	M10	70	126	63	16.6	34-46	0.17
06 560 004	P <sup>3/4"</sup> -12 D	ISO 12 B-2	M12	80	148	72	19.5	40-52	0.26

\* for SE sizes, please see table on page 40

## Chain Rider Type P

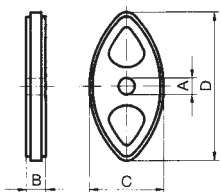

Art. No.	Type	Roller chain DIN 8187	A <sup>±0.2</sup>	B	C	D	Weight in kg
06 540 001	P <sup>3/8"</sup>	ISO 06 B	8	10.2	37	74	0.02
06 540 002	P <sup>1/2"</sup>	ISO 08 B	10	13.9	48	96	0.03
06 540 003	P <sup>5/8"</sup>	ISO 10 B	10	16.6	63	126	0.05
06 540 004	P <sup>3/4"</sup>	ISO 12 B	12	19.5	72	148	0.07

## Tensioning Roller

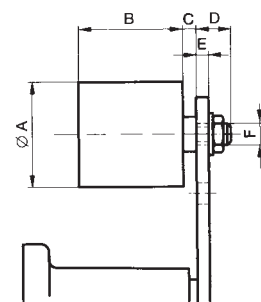

## Type R

Art. No.	Type	max. speed n/min.	A	B	C	D	E max.	F	Weight in kg
06 580 001	R 11	8000	30	35	2	14	5	M8	0.08
06 580 002	R 15/18	8000	40	45	6	16	7	M10	0.17
06 580 003	R 27	6000	60	60	8	17	8	M12	0.40
06 580 004	R 38	5000	80	90	8	25	10	M20	1.15
06 580 005	R 45	4500	90	135	10	27	12	M20	1.75



## Mounting Instructions



### Tensioning of "SE, SE-G and SE-W"

Bolt "A" is slightly tightened, the tensioning housing held with a position and turned in the required wrench. The bolt "A" is then tightened applying to the suitable torque  $M_A$ .



### Positioning, Angle Torsion Scale

The angle torsion scale "V" on the tensioner housing always shows the pretensioning angle. The positioning notch "P" on the housing flange allows easy readjustment of the pretensioning level when a corresponding mark is set up on the support or the machine part.



### Tensioning of "SE-F"

For applications on "blind" frame structures. The adjustment of the tension is made as described for type SE, but final fixation with hexagonal key front bolt.



### Chain Track

The chain tension sprocket, as well as the chain rider, is held between 2 nuts "C". The chain track can be set exactly by adjusting within the range R (see pages 41 and 42). Locknut "B" is always tight.



### Central Fixing

ROSTA tensioning elements are fitted centrally on a sufficiently strong, flat part of the machine. If a direct mounting is not possible, we recommend to use the support **type WS** (see page 24).



### "Z"-Arrangement

If chain tension sprockets/chain riders or tensioning rollers are mounted on the outside of the lever, the spacing "Z" should be as little as possible. The max. tension F must not then exceed 50% = approx. 20° of pretension.



## Mounting Instructions

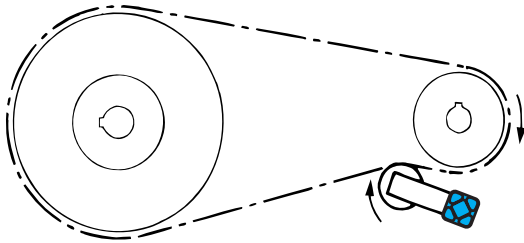

### Normal Positioning

The ROSTA tensioning elements are always positioned on the slack side of the chain. They should be fitted as close as possible to the big wheel and guide the chain from the outer side. **The ideal position of the tensioning arm is nearly parallel to the chain drive.**

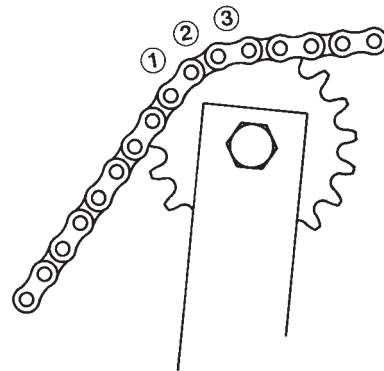

### Chain Engagement

At least 3 teeth of the sprocket wheel must engage into the roller chain when tensioning the chain for the first time. The minimum number of engaged sprocket teeth between the tensioning wheel and chain strand is 3.

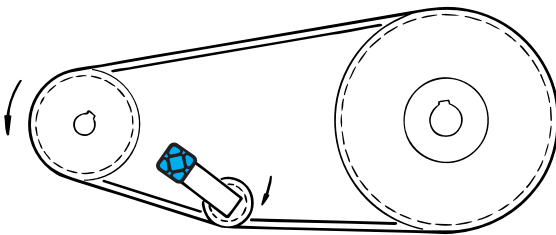

### V-belt Tensioner – Inner Grooved Pulleys

V-belt pulleys can be mounted as inner rollers at any position on the slack side of the V-belt (For drives with long axial distances and a high level of vibration we recommend to use pulleys with deep grooves).

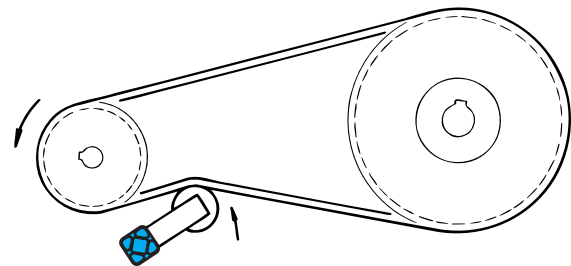

### V-belt Tensioner – Outer Roller

Please refer to the instructions of the belt manufacturer for further information on the belt structure when mounting our ROSTA belt tensioning elements with flat rollers on the back of the belt. Inner or outer tension rollers must be positioned as far away as possible from the next V-belt pulley the belt is guided to.

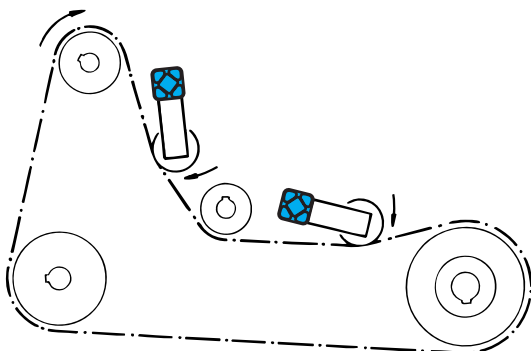

### Mounting

The chain tensioner must be adjusted in the axial and angular direction. The tensioning arm should be nearly in parallel position to the chain and in the direction of the chain's drive. In case the chain drives are extremely long it is possible to fit several chain tensioners in order to obtain better tensioning and compensation.

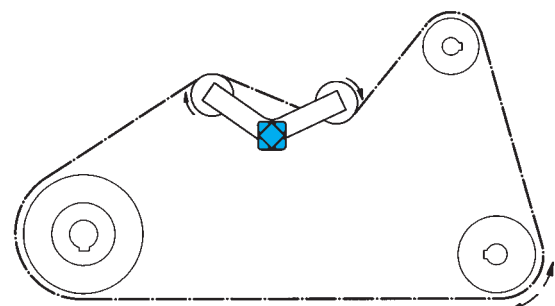

### Application Field of the SE-B "Boomerang" Tensioner

In the past two or even three ROSTA tensioner type SE had to be installed on very long chain or belt drives to compensate the initial elongation. The new "Boomerang" with its distinguished elbow lever arm shape and the combination of two sprocket wheels or a V-belt pulley with a roller type R, offers a triple slack compensation on the loose drum than a standard tensioner.



## Applications



Suspension of tensioning rollers on a wrapping machine



Suspension of circular brush on potato harvester



Belt tensioner on belt drive between diesel engine and AC-compressor



Belt tensioner on belt drive for an AC-compressor



Belt tensioner on belt drive between diesel engine and an alternator



Suspension of tensioning rollers on milling machine in the wood industry



Elastic suspension on belt scraper



## Applications



Chain tensioner on drilling machine in mining industry



Chain tensioner on baling press



Boomerang chain tensioner on farming machine



Chain tensioner with glider on processing machine



Elastic chain guidance on wood intake



Chain tensioner on paper rolling mechanism



Belt tensioner on material intake in a grinding machine